

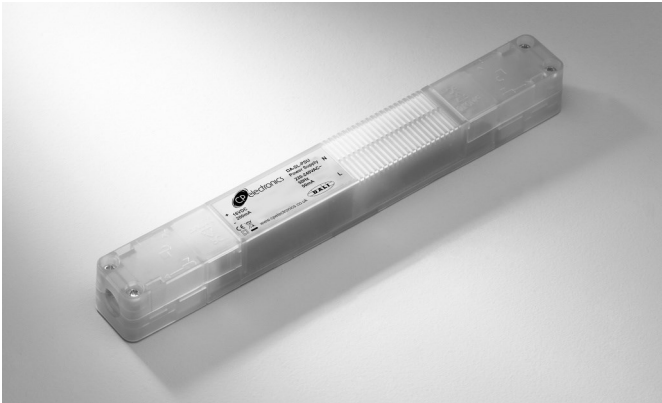

DA-SL-PSU

DALI SL Power Supply

Overview



The DA-SL-PSU is an SELV 16VDC power supply primarily designed for DALI. The unit has an integral LED that is visible through the front window to indicate that the output voltage is healthy.

This unit can be used with the following systems and products

- DALI lighting control systems.
- **An-10[®]** AT-BB-IN wireless (RF) switch input unit where latching switches are used.
- Use in conjunction with **EBDHS-B32-SR-MP** (SR highbay detector head) to control standard DALI drivers.

Installation

Mount and wire the unit in the following method.

- Remove terminal covers by unscrewing the clamp screws and inserting a small flat-bladed screwdriver into the slots shown in the diagram below.
- Affix the DA-SL-PSU using the fixing slots shown in the diagram below .
- The fixing slots are suitable for M4 screws.
- Wire unit using the screw terminals.
- The screw terminals are suitable for solid core or stranded cable up to 2.5mm². Maximum cable OD 10mm.
- Ensure that the main cable sheathing is over the cable clamp area. Clip on the terminal covers.
- Insert the clamp screws and screw up until the cable is firmly clamped.

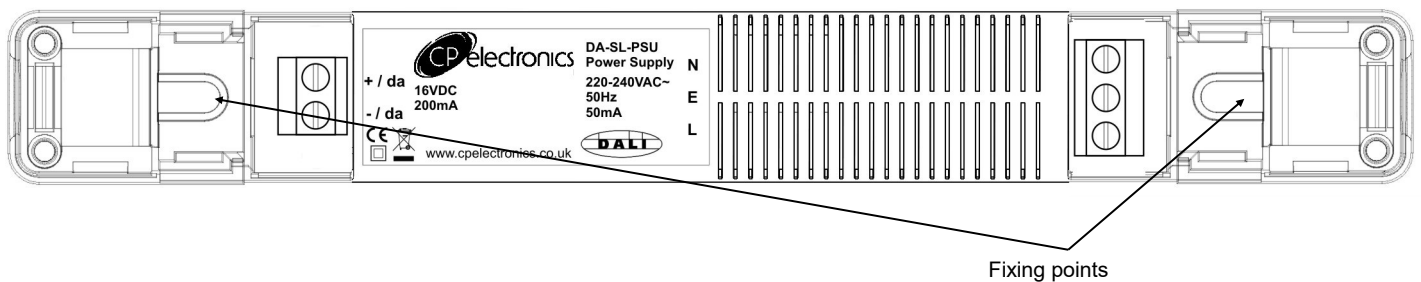
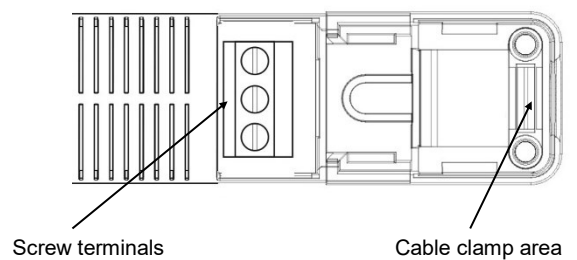
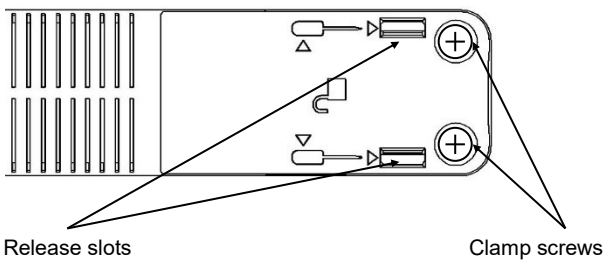

Wiring

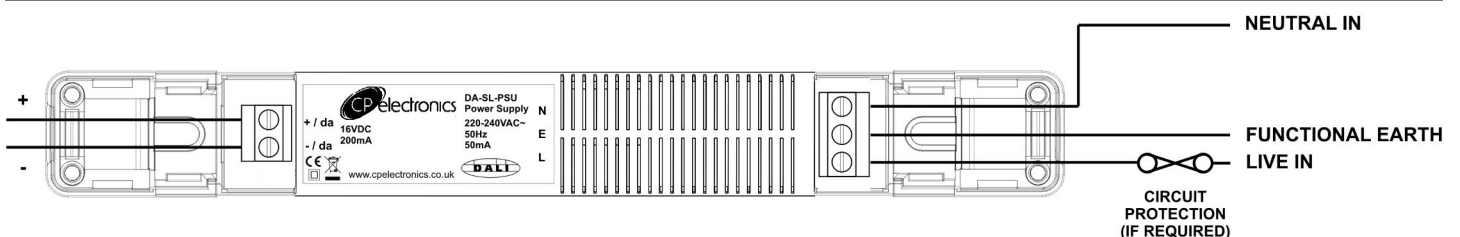

- DA-SL-PSU can be used in conjunction with SR highbay detector head EBDHS-B32-SR-MP to control standard DALI drivers
- Please follow the instructions as per opposite diagram.

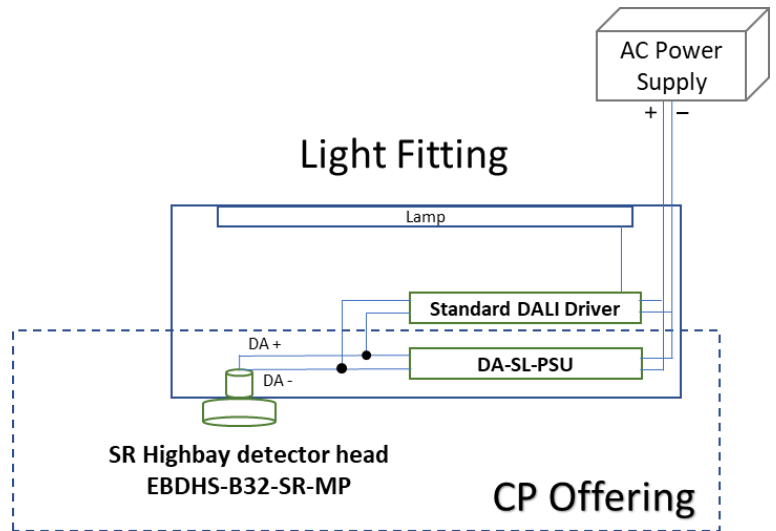

Technical data

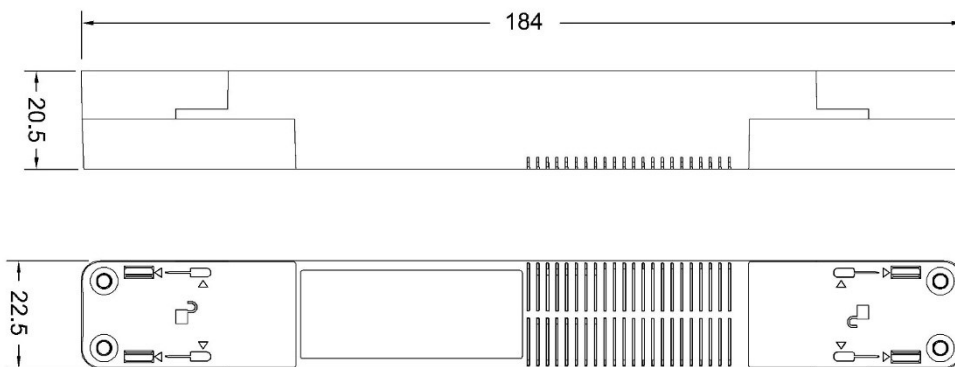

Dimensions	See diagrams above
Weight	0.07kg
Input Voltage	220-240VAC
Input Current	50mA
Input Frequency	50Hz
Output Voltage	16VDC +/- 2V SELV
Output Current	200mA (maximum)
Terminal Capacity	2.5mm ² Solid and stranded. Maximum cable OD 10mm.

Safety Note



Temperature
Humidity
Material (casing)
Compliance

DALI is not SELV. If this product is used in a DALI system then mains rated wiring must be used for the output.

0°C to 35°C
5 to 95% non-condensing
Flame retardant polycarbonate
EMC-2004/108/EC

Part numbers

	Part number	Description
Power supply	DA-SL-PSU	DALI SL Power Supply
Addressers	DA-SL-ADD	DALI addresser-DIL-DALI/DSI
	DA-SL-ADDR	DALI addresser-DIL-DALI/DSI-relay
	DA-SL-ADAR	DALI addresser-DIL-1-10V-relay
An-10 Highbay SR (Sensor Ready) detector head	AT-BB-IN	An-10 RF input unit
	EBDHS-B32-SR-MP	High Sensitivity highbay SR detector head

IMPORTANT NOTICE!

This device should be installed by a qualified electrician in accordance with the latest edition of the IEE Wiring Regulations and any applicable Building Regulations.



C.P. Electronics Ltd
Brent Crescent
London
NW10 7XR
United Kingdom
Tel: + 44 (0) 333 900 0671
Fax: + 44 (0) 333 900 0674
www.cpelectronics.co.uk
enquiry@cpelectronics.co.uk